

Operators and Service Manual



Product Holding Unit

U.S. Patent 6175099, 6262394

Other U.S. and Foreign Patents Pending

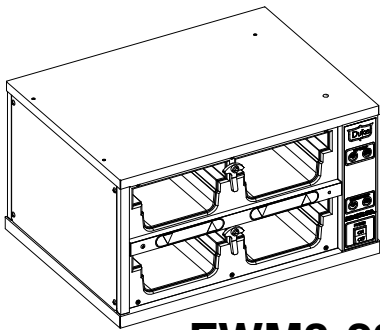

FWM3-22

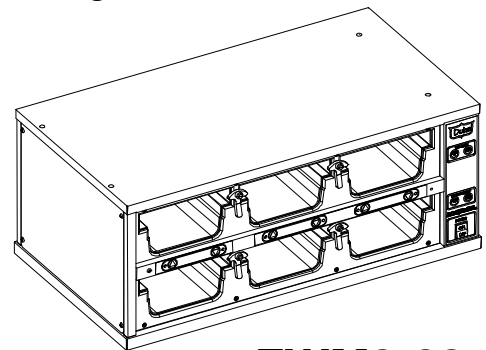

FWM3-23

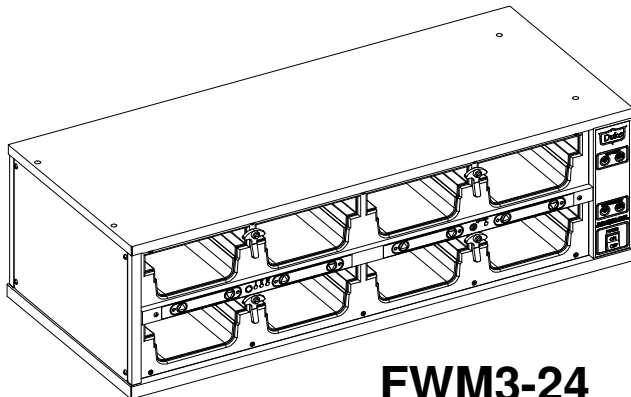

FWM3-24

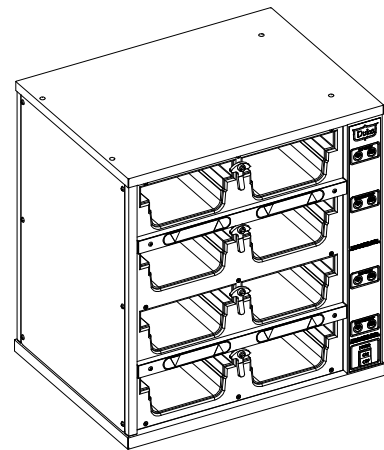

FWM3-42

For information or technical assistance, call:

TOLL FREE

(800) 735-DUKE (3853)

or

(314) 231-1130

For information or technical assistance on the ICC Product Quality
Timer System, call:

(877) 422-8788

TABLE OF CONTENTS

Manufacturer’s Introduction3
 Specification Sheet.....4
 Installation Instructions.....8
 Stacking Units8
 Unit to Unit Communication Connections9
 Periodic Maintenance, Checklist And Cleaning Guide10
 Troubleshooting.....11
 Electronic Control Fault Indications11
 Temperature Check Procedure.....11
 Control Programming.....12
 Parts Lists And Illustrations13
 Wiring Schematic.....15

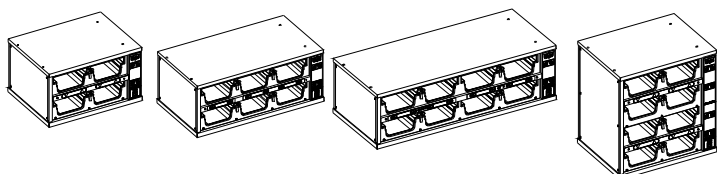

Manufacturer’s Introduction

The Duke Product Holding Unit was developed in response to Burger Kings need for extended food-holding capabilities to provide consistently high, “just cooked” food quality as part of the HIYW kitchen.

The Duke Product Holding Unit utilizes Duke’s patented “heat sink” holding technology that provides even heat distribution to food pans through the bottom and sides. This allows pre-cooked foods to be held for extended periods without noticeable degradation of quality, reducing food scrap/waste.

The self contained, individually formed, sealed compartments of the Duke Product Holding Unit eliminates food odor and taste transfer.

Because the compartments are sealed and formed to the shape of the pan, no disassembly is required for cleaning and product changes.

The unique design of the Duke Product Holding Unit allows single temperature operation for all existing product groups. This 190° F approved temperature is preset at the factory. This reduces the likelihood of inconsistent performance between Burger King restaurant locations.

The Duke Product Holding Cabinet was also designed to rethermalize food product. A thermostat setting of 200° F minimum is required for rethermalization. See instructions on page 12 for thermostat adjustment. **NOTE:** Only qualified service persons should modify control temperature presets.

Supplier Name: **Duke Manufacturing Co.**
 Address: 2305 N. Broadway
 St. Louis, MO 63102

Model #:	FWM3-22-120	FWM3-24-120
	FWM3-22-208	FWM3-24-208
	FWM3-22-230	FWM3-24-230
	FWM3-22-240	FWM3-24-240
	FWM3-23-120	FWM3-42-120
	FWM3-23-208	FWM3-42-208
	FWM3-23-230	FWM3-42-230
	FWM3-23-240	FWM3-42-240

Serial #: _____
 Date Received: _____
 Date Installed: _____
 Telephone : (800) 735-DUKE (3853)
 (314) 231-1130
 Fax: (314) 231-5074
 Service Referral #: _____
 Local Service Name _____
 Local Service # _____

Installation requirements

Power Connection: See diagrams on pages 2-5.

!CAUTION!
Risk of fire or electric shock. Replace only with Manufacturer’s cord set or equivalent.



**Figure 1.1, FWM Specification Sheet
Model FWM3-22**

Shipping Weight:	61 lbs/27.7 Kg	
Electrical:	FWM3-22-120 FWM3-22-208 FWM3-22-230 FWM3-22-240	120 V, 6.7 A, 800 W, 50/60 Hz 208 V, 5.8 A, 1200 W, 50/60 Hz 230 V, 5.2 A, 1200 W, 50/60 Hz 240 V, 5.0 A, 1200 W, 50/60 Hz

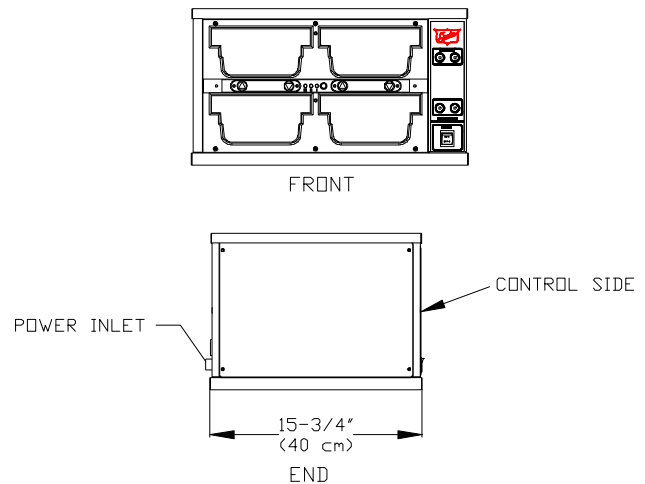
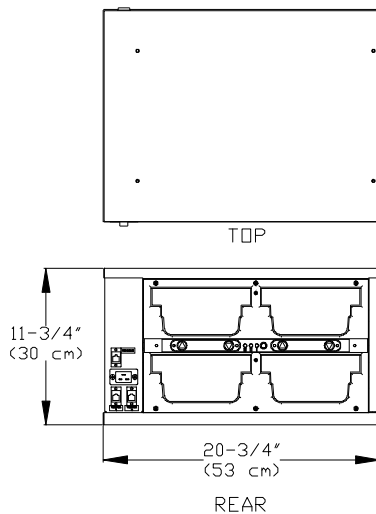
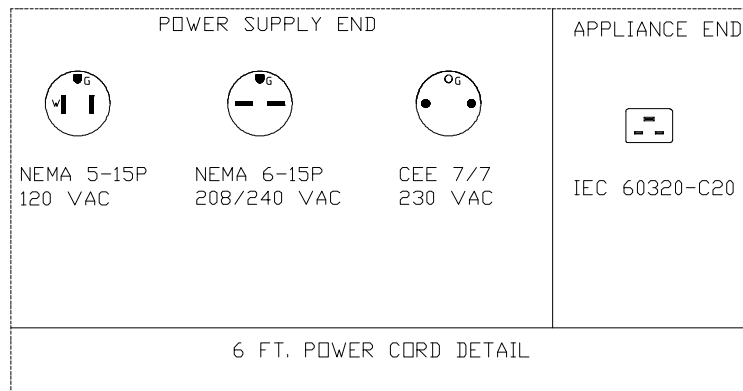
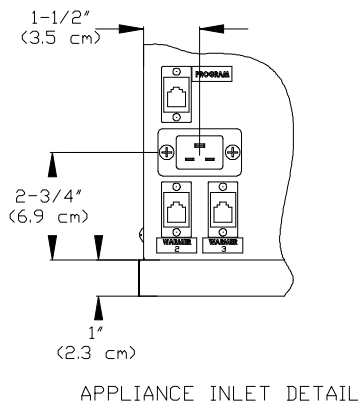

ALSO CLASSIFIED BY
UNDERWRITERS LABORATORIES INC.
IN ACCORDANCE WITH
NSF NO. 4 1999



REVISED:
Feb. 21, 2005

U.S. Patent 6175099, 6262394
Other U.S. and Foreign Patents Pending
DUKE MANUFACTURING CO.
TOLL FREE 800-735-DUKE (3853)
314-231-1130



**Figure 1.2, FWM Specification Sheet
Model FWM3-23**

Shipping Weight:	83.5 lbs/37.9 Kg	
Electrical:	FWM3-23-120 FWM3-23-208 FWM3-23-230 FWM3-23-240	120 V, 10.0 A, 1200 W, 50/60 Hz 208 V, 8.7 A, 1800 W, 50/60 Hz 230 V, 7.8 A, 1800 W, 50/60 Hz 240 V, 7.5 A, 1800 W, 50/60 Hz

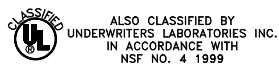
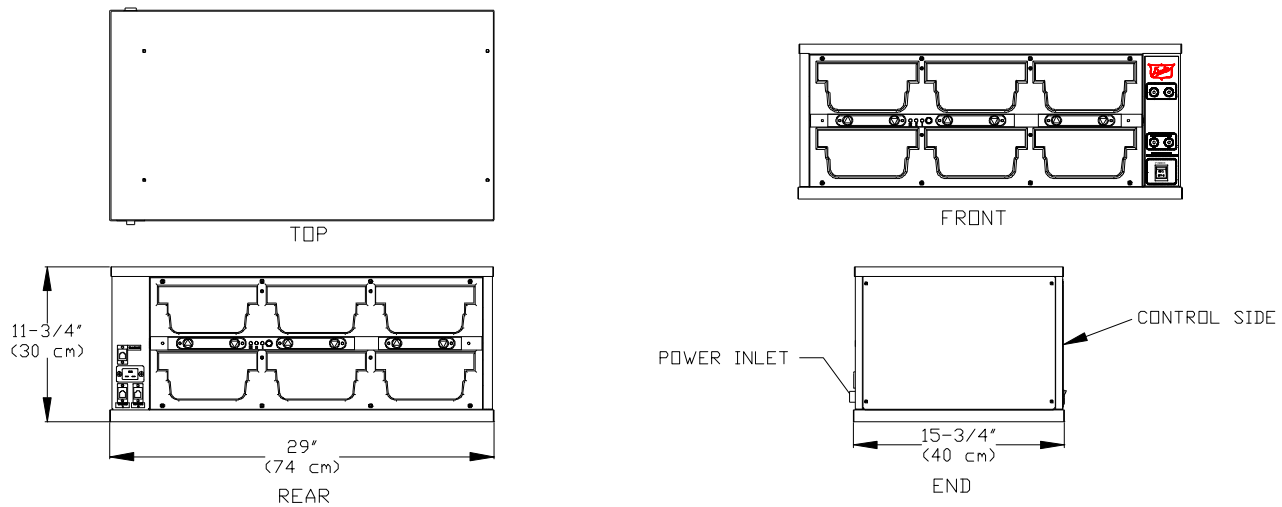
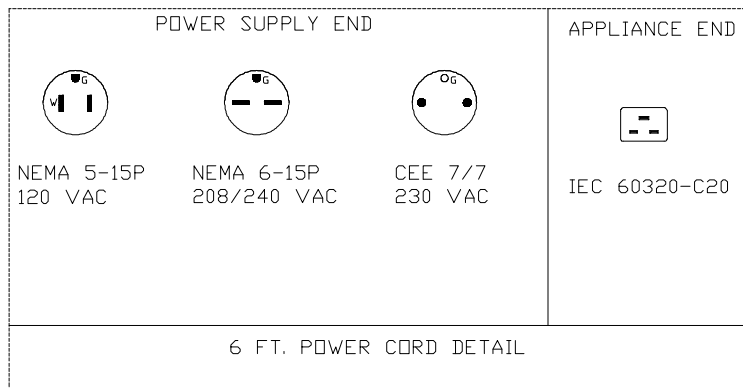
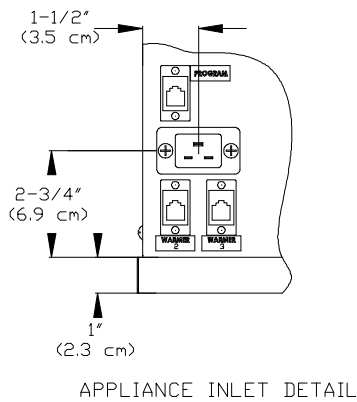

**Figure 1.3, FWM Specification Sheet
Model FWM3-24**

Shipping Weight:	100 lbs/45 Kg	
Electrical:	FWM3-24-120 FWM3-24-208 FWM3-24-230 FWM3-24-240	120 V, 13.3 A, 1600 W, 50/60 Hz 208 V, 11.5 A, 2400 W, 50/60 Hz 230 V, 10.4 A, 2400 W, 50/60 Hz 240 V, 10.0 A, 2400 W, 50/60 Hz

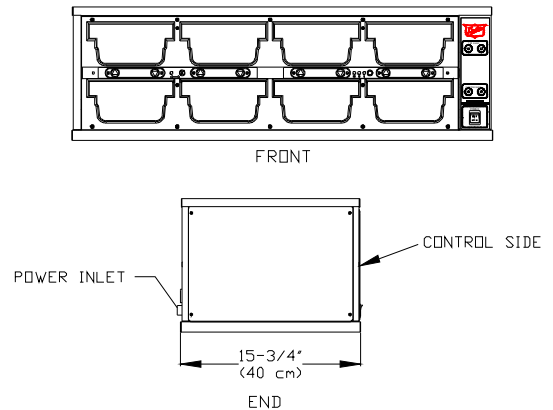
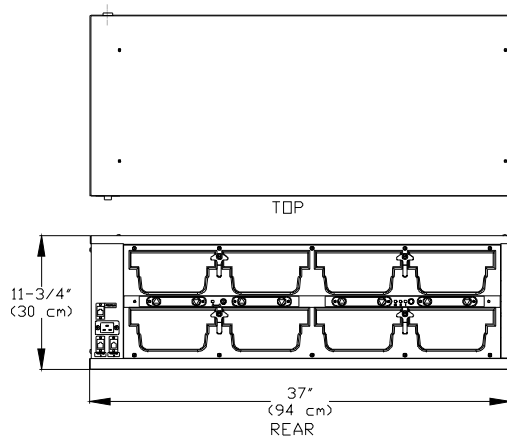
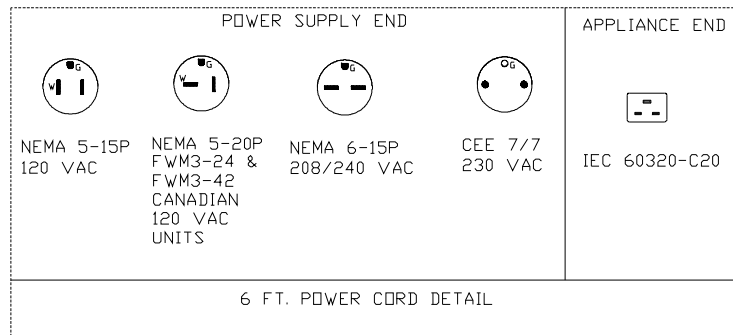
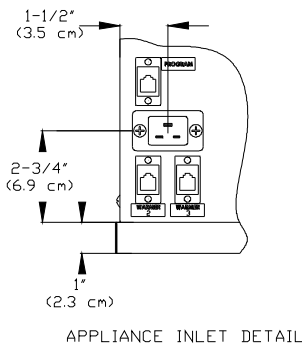

ALSO CLASSIFIED BY
UNDERWRITERS LABORATORIES INC.
IN ACCORDANCE WITH
NSF NO. 4 1999



REVISED:
Feb. 21, 2005

U.S. Patent 6175099, 6262394
Other U.S. and Foreign Patents Pending
DUKE MANUFACTURING CO.
TOLL FREE 800-735-DUKE (3853)
314-231-1130



**Figure 1.4, FWM Specification Sheet
Model FWM3-42**

Shipping Weight:	100 lbs/45 Kg	
Electrical:	FWM3-42-120	120 V, 13.3 A, 1600 W, 50/60 Hz
	FWM3-42-208	208 V, 11.5 A, 2400 W, 50/60 Hz
	FWM3-42-230	230 V, 10.4 A, 2400 W, 50/60 Hz
	FWM3-42-240	240 V, 10.0 A, 2400 W, 50/60 Hz

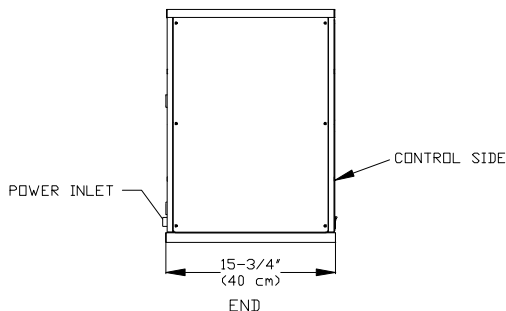
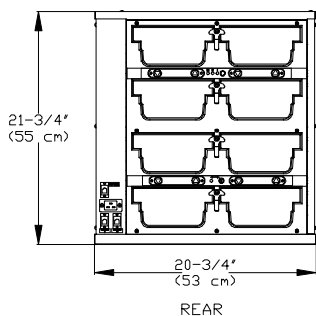
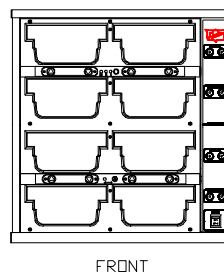
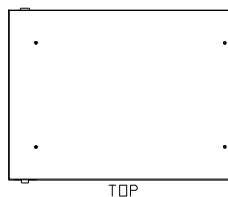
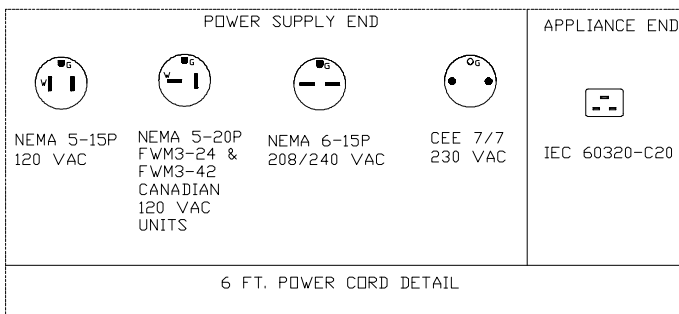
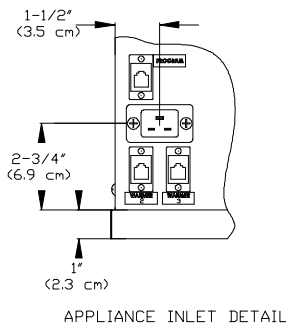

ALSO CLASSIFIED BY
UNDERWRITERS LABORATORIES INC.
IN ACCORDANCE WITH
NSF NO. 4 1999



REVISED:
Feb. 21, 2005

U.S. Patent 6175099, 6262394
Other U.S. and Foreign Patents Pending
DUKE MANUFACTURING CO.
TOLL FREE 800-735-DUKE (3853)
314-231-1130



Installation Instructions

1. Place holding unit onto stable surface.
2. Attach power supply cord to IEC 60320 C20 using approved cordset.
3. Follow instructions in the Operators Manual PERIODIC MAINTENANCE, CHECKLIST AND CLEANING GUIDE.

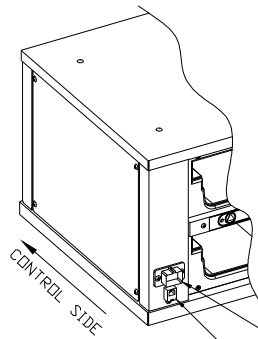

IEC 60320-C20 (DUKE P/N 155741) POWER INLET WITH 156332 CORD CLAMP
RJ-12 DATA CONNECTION

!CAUTION!

Risk of fire or electric shock. Replace cord with one of the following Duke cordsets only:

- P/N 156533 Cordset, NEMA 5-15P, 120 V
- P/N 156811 Cordset, NEMA 5-20P, 120 V Canadian FWM3-24 & FWM3-42 units
- P/N 156421 Cordset, NEMA 6-15P, 208/240 V
- P/N 156400 Cordset, 230 V CE

Screw



The proper way to connect the power cord is to loosen the screw, push the cord fully into the holder and then retighten the screw

Stacking Units

The FWM3-24 Product Holding Unit is designed to allow limited stacking capabilities. This section outlines how to safely stack the holding cabinet.

Step 1

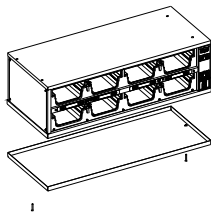

Remove the base pan from all holding units, except for bottom unit, that are to be stacked. The pan is held in place by two screws on the bottom of the unit.

Step 2

Place bottom unit into position then stack the next unit on top. The top of the lower holding unit rests inside of the base of the upper unit.

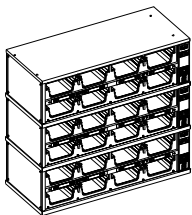
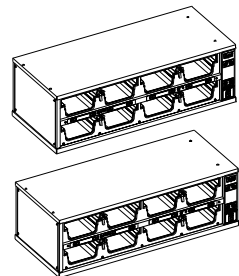

WARNING!

TIP HAZARD! Do not stack FWM3-42 units. Do not exceed 3 holding units per stack. Do not place holding unit stacks on surfaces that may easily tip over.



Unit to Unit Communication Connections

The following are the two different field connections, i.e. Specialty Board and Main Board.

Main Board Field Connection

The MB-1 Main Board Unit that has the ICC Black Box internally mounted can be identified as the warmer with timer bars on both sides and plug connections numbered Warmer #2 and #3 as shown in Figure 2.1. This unit is internally wired and ready to operate. Should your restaurant have two or more units on the main board the second or third unit can be identified as the warmer with timer bars on each side and one plug connection as shown in Figure 2.1. To put this second unit into operation connect the provided cable between the #2 plug connection on the MB-1 and the single plug connection on the MB-2 unit. To put the third warmer into operation connect the provided cable between the #3 plug connection on the MB1 and the single plug connection on the MB2. The ICC steamer bar, if provided, plugs into the #3 plug connection on the MB1 unit as shown in figure 2.1. The program connection is used with the ICC provided Palm Pilot programming device.

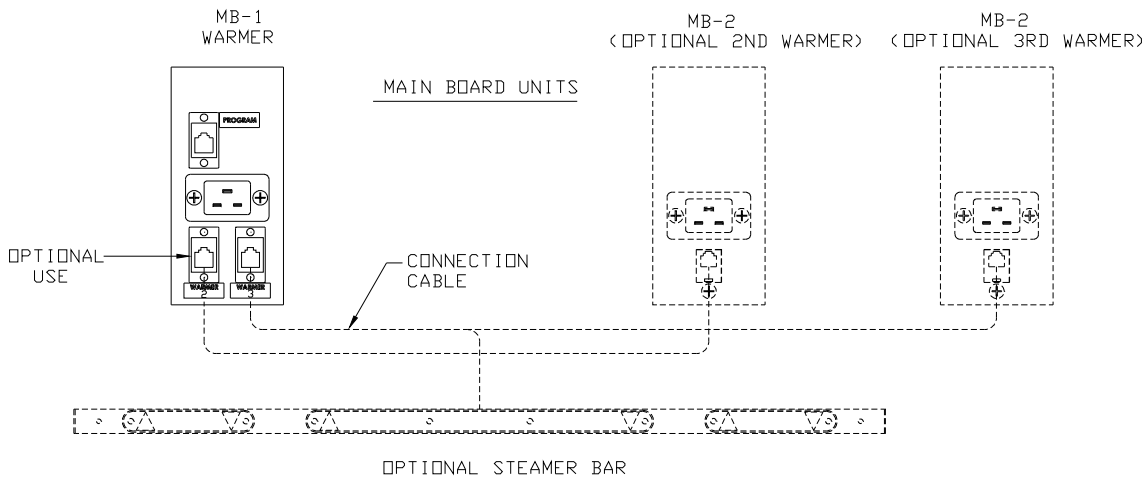

Figure 2.1

Specialty Board Field Connection

The SB-1 Specialty Board Unit that has the ICC black box internally mounted can be identified as the warmer with one timer bar and plug connections numbered Warmer #2 and #3 as shown in Figure 2.2. This unit is internally wired and ready to operate. The SB-2 Specialty board Unit has one timer bar and one plug connection as shown in Figure 2.2. To put this unit into operation connect the provided cable between the #2 plug connection on the SB-1 and the single plug connection on the SB-2 unit. The #3 plug on the SB1 is used if a third SB2 warmer is added.. The program connection is used with the ICC provided Palm Pilot programming device.

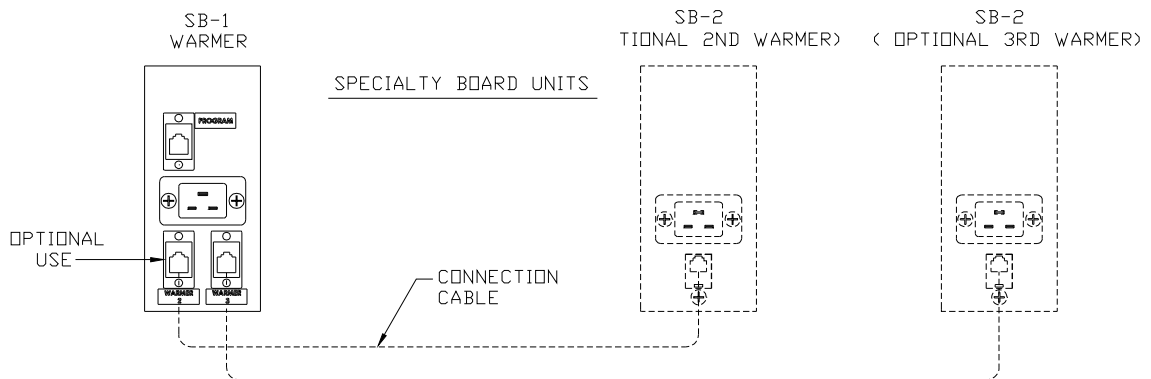
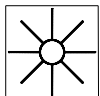

Figure 2.2



Periodic Maintenance, Checklist And Cleaning Guide

DAILY



Opening Checklist

1. Ensure proper **Pan Covers** are inserted into the correct locations for fried and broiled products.
2. Place the **Power Switch**, located on the front of the Product Holding Unit, to the ON position.
3. Ensure both top and bottom **HEAT Lights** are illuminated.
4. Allow the Product Holding Unit to heat for at least 20 min. or until the **HEAT Lights** cycle off.

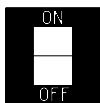

Operation Instructions/Adjustments

1. If the **SERVICE Light** illuminates during operation of the Product Holding Unit, discontinue use of the affected shelf until the module is serviced.
2. Operate using Menu Bar as outlined in the Menu Scoreboard Operators Manual.



Closing Checklist

1. Turn power switch OFF.
2. Remove all pans and pan covers.
3. Allow to cool for approximately 30 minutes.
4. Clean Product Holding Unit as outline in the Daily Cleaning Instructions.

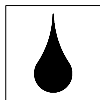

Cleaning Instructions

1. Wipe down the interior and exterior of the Product Holding Unit with warm water and mild detergent using a soft cloth. Do not use excessive amounts of water.
2. Clean pans and pan covers using mild detergent and warm water. Ensure all soap is rinsed from plastic pans and pan covers.

Caution!

**Electrical shock hazard. Do not wash with water jet or hose.
Do not use caustic cleaners, acids, ammonia products or abrasive cleaners or
abrasive cloths. These can damage the stainless steel and plastic surfaces.**

!Warning!

Bottom and sides of warmer wells are very hot and cool slowly.



Troubleshooting

There are no user serviceable parts on the Duke Product Holding Unit. If a malfunction occurs, ensure unit is plugged in then check all switches and circuit breakers. If the malfunction still exists, contact your Duke Manufacturing Company authorized service agent or call 1-800-735-3853.

Electronic Control Fault Indications

The Service Light is located on the front of the control next to the heat light (see Figure 3). It provides an indication to alert the operator to failures in the heater circuit. When a Service Light is on, the affected shelf should not be used until the cause of the fault is corrected by a qualified service technician. The fault conditions that could cause the control to turn the service light on are as follows:

1. **Over – Temperature Fault** - An over-temperature fault occurs when the control senses that the shelf temperature is higher than the specified factory preset temperature. This occurs when the power is not removed from the heating element after the shelf has achieved the preset temperature, causing the control to turn on the service light. The auxiliary thermostat prevents the temperature from exceeding safe levels by regulating the temperature to a maximum of 250° F.
2. **Under – Temperature Fault** - An under-temperature fault occurs when the control senses that the shelf temperature is lower than the specified factory preset temperature for more than 30 minutes continuously. This occurs when heating element circuit opens or the RTD Feedback signal is faulty, causing the control to turn on the service light.

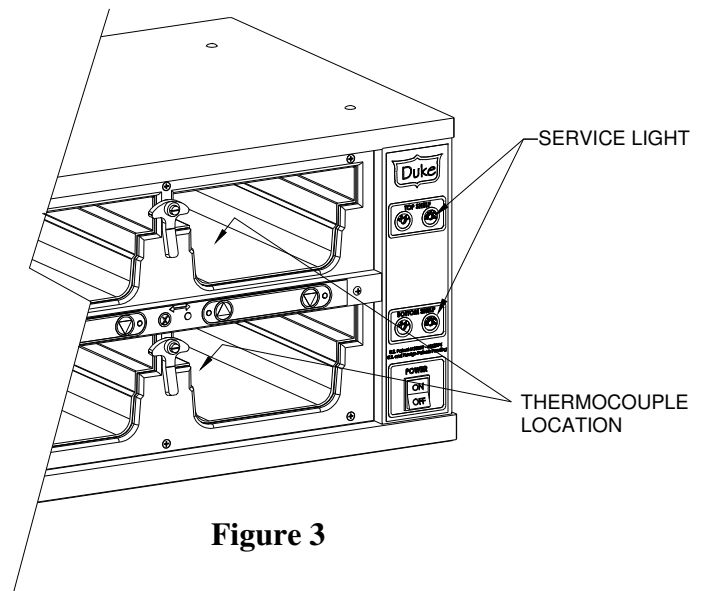

Figure 3

Temperature Check Procedure

1. A digital temperature meter that has been calibrated must be used to get an accurate temperature reading. Use a thermocouple surface temperature probe to measure temperatures.
2. **No pans should be in wells during the pre-heat and temperature check.** Pre-heat the warmer for 30 minutes before taking any temperature readings. Do not take readings unless the cavity has been empty for 30 minutes. This will allow the temperature to stabilize and will prevent false readings.
3. The warmer cavity should be cleaned and empty before the temperature is checked. Avoid any air drafts that might flow through the cavity.
4. Locate the surface temperature probe on the bottom of the first cavity in the geometric center. The first cavity is the one closest to the control panel (see Figure 3). Make sure the probe is making good contact with the surface while taking readings.
5. All temperature controls exhibit a swing in temperature as the control cycles on and off while regulating to the set point. The correct calibration temperature is the average of several readings taken over a period of 20 minutes after the warmer has been pre-heated. The average temperature should be $\pm 5^{\circ}\text{F}$ from the set point.



Control Programming

The electronic temperature control is pre-set at the factory to maintain the temperature at the bottom center of the pan cavity at 190° F +/- 5° F. This temperature is the result of many hours of food testing at the Burger King test laboratory. There are no operator temperature adjustments that can be made. Because the electronic control uses a platinum type RTD sensor, routine calibration is not required.

**!DANGER!
LIVE ELECTRICAL COMPONENTS.
ONLY QUALIFIED SERVICE PERSONS SHOULD MODIFY CONTROL
TEMPERATURE PRESETS.**

Temperature Programming

1. Remove cover from control side of the Holding Unit and turn the Holding Unit on.
2. Locate the pushbutton S1 and S2 on the rear of the control. (see Figure 4.1)
3. Press and hold S1 until any LED on the rear of the control illuminates. (approximately 5 seconds)
4. Observe the front of the control (Figure 4.2). Press and release S1 on the back of the control until the desired light on the front of the control flashes. (see Table 1)

NOTE: To comply with NSF sanitation requirements, do not set the control preset temperature below 190° F.

5. Press and release S2 until the sum of the LED values illuminated on the rear of the board match the desired pre-set temperature.
6. Repeat steps 4 and 5 for each pre-set temperature then press and hold S1 until no LED on the rear of the control is illuminated and the lights on the front of the board no longer flash.
7. Replace cover on control side of the Holding Unit.

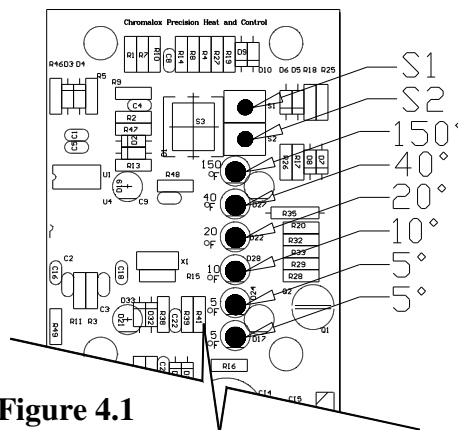

Figure 4.1

Flashing Lights		
	A	B
Top Shelf	X	
Bottom Shelf		X

TABLE 1

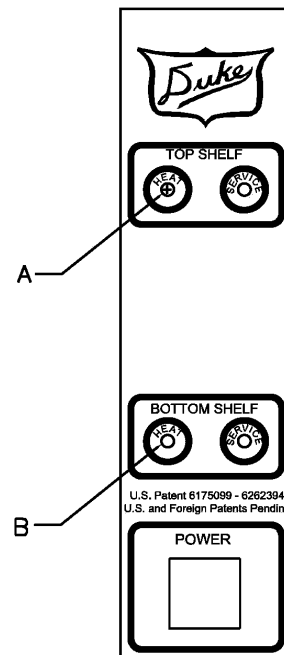

Figure 4.2



Parts Lists and Illustrations

Locator	P/N	Description	Qty Per Unit				
			FWM3-22	FWM3-23	FWM3-24	FWM3-42	
2	600106	KIT, FWM CONTROLLER	1	1	1	2	
3	155749	TRANSFORMER 208/230CE/240 VAC	1	1	1	1	
	156838	TRANSFORMER 230 VAC					
	156316	TRANSFORMER 120 VAC					
4	155741	RECEPTACLE ELECTRIC	1	1	1	1	
5	156616	COUPLER 6X6 RJ12 (MB1 & SB1 UNITS ONLY)	2	2	2	2	
6	156617	COUPLER, 8X8 RJ45 (MB1 & SB1 UNITS ONLY)	1	1	1	1	
7	156059	CONNECTOR SPECIAL T (REAR VIEW MB2 & SB2)	1	1	1	1	
8	156527	SWITCH, LIGHTED, DPST, 16A	1	1	1	1	
10	156485	FACE PLATE WITH GASKET, FWM3-22	2	2	2	2	
	156558	FACE PLATE WITH GASKET, FWM3-23					
	155849	FACE PLATE WITH GASKET, FWM3-24					
	156548	FACE PLATE WITH GASKET, FWM3-42					
11	156285	LATCH,PAN	4	8	8	8	
12	156288	SCREW SHOULDER	4	8	8	8	
13	0653638	SCREW 1/4-20 X 3/4	8	8	8	16	
14	155750	RTD 1K OHM THIN	2	2	2	4	
15	156483	ELEMENT FOIL HEAT FWM3-22-120 & FWM3-42-120	4	6	8	8	
	156539	ELEMENT FOIL HEAT FWM3-22-208 & FWM3-42-208	4				
	156632	ELEMENT FOIL HEAT FWM3-22-230CE & FWM3-42-230CE	4				
	156540	ELEMENT FOIL HEAT FWM3-22-240 & FWM3-42-240	4				
	156564	ELEMENT FOIL HEAT FWM3-23-120					
	156301	ELEMENT FOIL HEAT FWM3-23-208					
	156611	ELEMENT FOIL HEAT FWM3-23-230CE					
	156565	ELEMENT FOIL HEAT FWM3-23-240					
	156566	ELEMENT FOIL HEAT FWM3-24-120					8
	155752	ELEMENT FOIL HEAT FWM3-24-208					8
156318	ELEMENT FOIL HEAT FWM3-24-230CE		8				
155755	ELEMENT FOIL HEAT FWM3-24-240		8				
16	155753	THERMOSTAT AUXILIARY	2	2	2	4	
17	155680	NUT #8-32 KEPS	4	4	4	8	
18	155873	LID,FOODWARMER VENTED (FRIED)(GRAY)	AR	AR	AR	AR	
19	155876	LID,FOODWARMER SOLID (BROILED)(BLACK)	AR	AR	AR	AR	
20	156491	CABLE, 8 FT, (FOR INTERCONNECTING UNITS)(NOT SHOWN)	AR	AR	AR	AR	
21	156533	CORDSET, NEMA 5-15P, 120V (NOT SHOWN)	1	1	1	1	
	156811	CORDSET, NEMA 5-20P, 120V, CANADIAN FWM3-24,-42 (NOT SHOWN)					
	156421	CORDSET, NEMA 6-15P, 208/240V (NOT SHOWN)					
	156400	CORDSET, 230V CE (NOT SHOWN)					
22	156938	TERMINAL BLOCK	1	1	1	1	



Parts Lists and Illustrations (Continued)

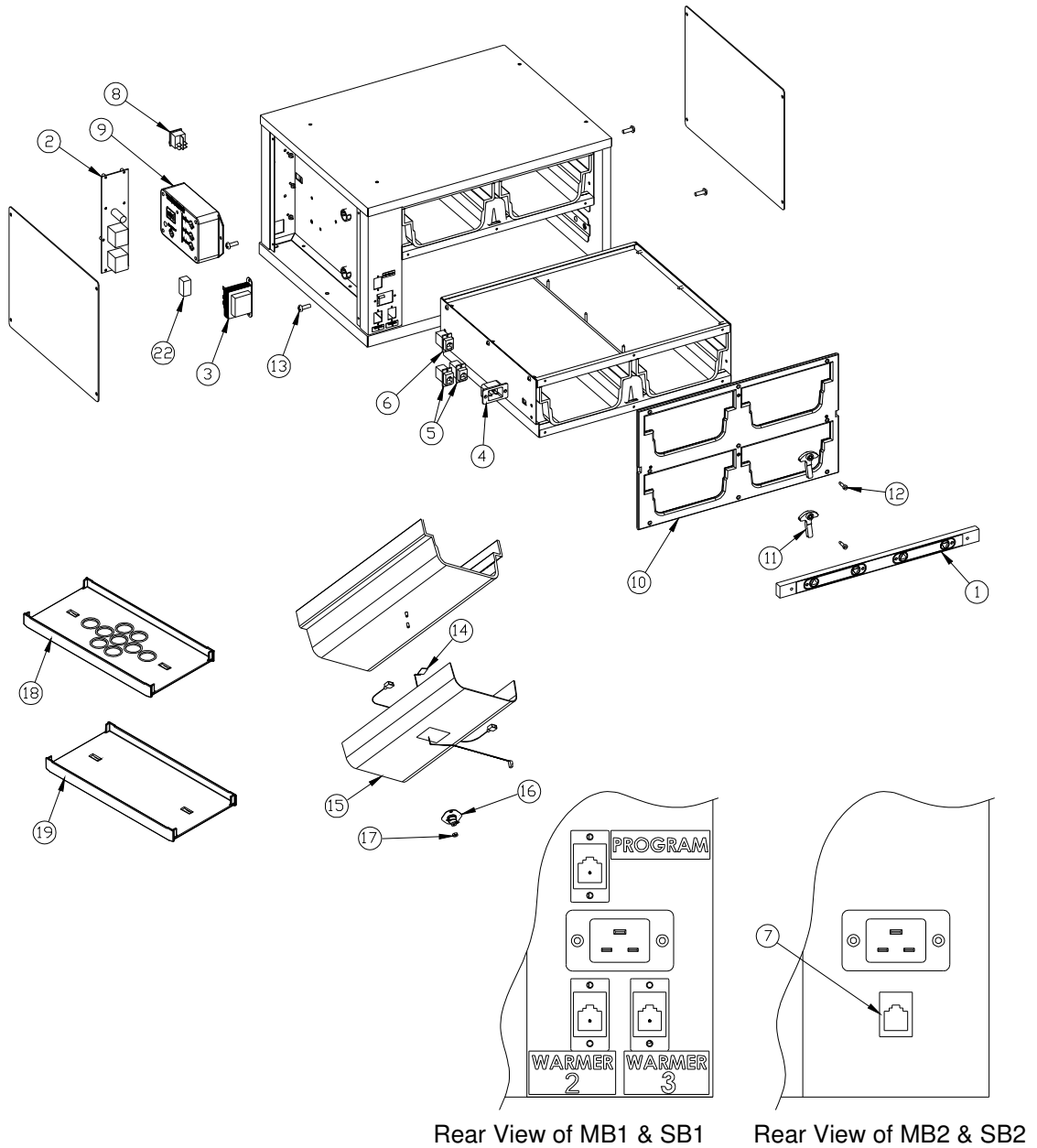
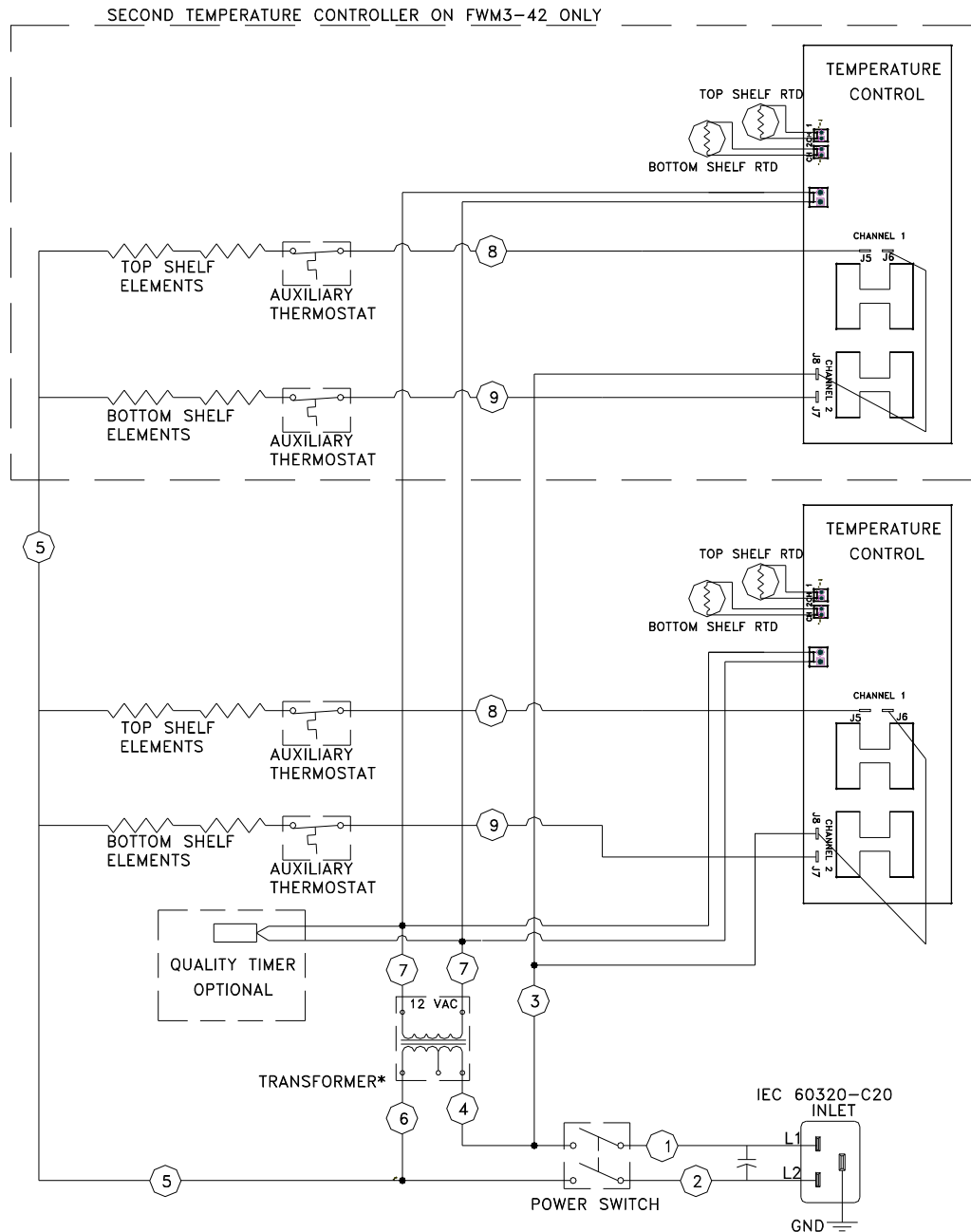

Figure 5, FWM Product Holding Unit Exploded View



Wiring Schematics



* CONNECT WIRE #4 TO 240V TERMINAL FOR 240VAC AND 230VAC CE UNITS (SHOWN)
CONNECT WIRE #4 TO 208V TERMINAL FOR 208 VAC UNITS
120 VAC UNITS USE A 120V TRANSFORMER

Figure 6, FWM Internal Wiring Schematic



Wiring Schematics (Continued)

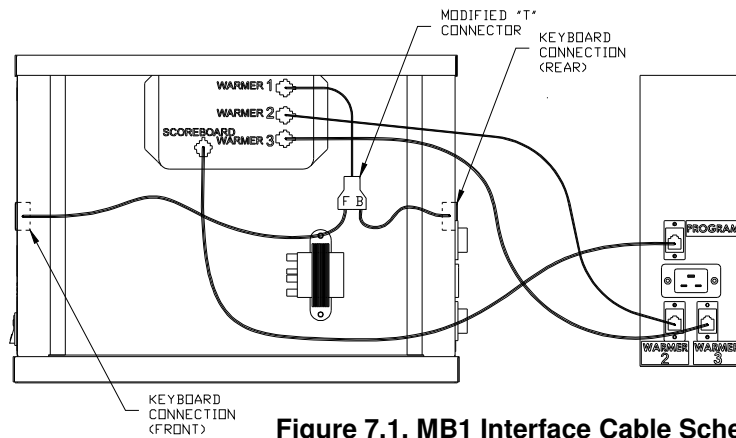

Figure 7.1, MB1 Interface Cable Schematic

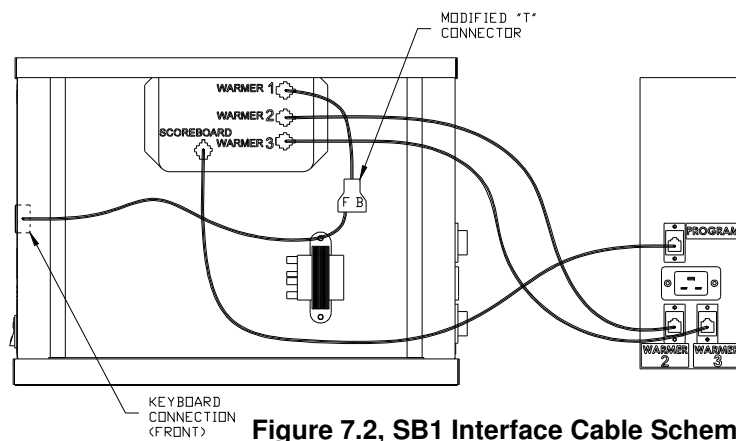

Figure 7.2, SB1 Interface Cable Schematic

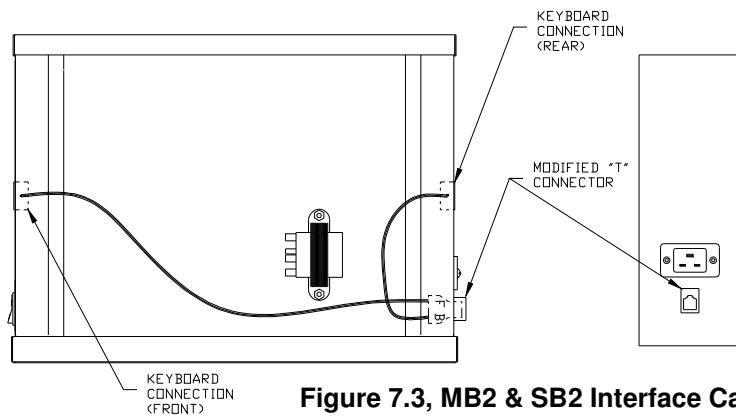

Figure 7.3, MB2 & SB2 Interface Cable Schematic



FWM3-42 Wiring Schematics

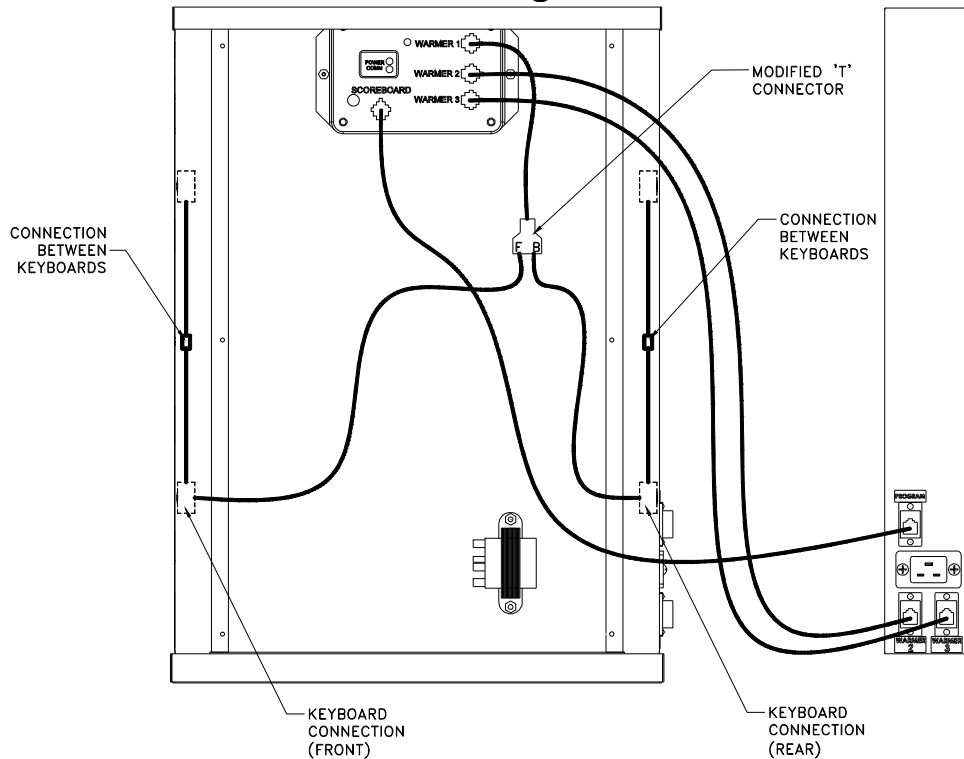

Figure 7.4 FWM 3-42 MB1 Interface Cable Schematic

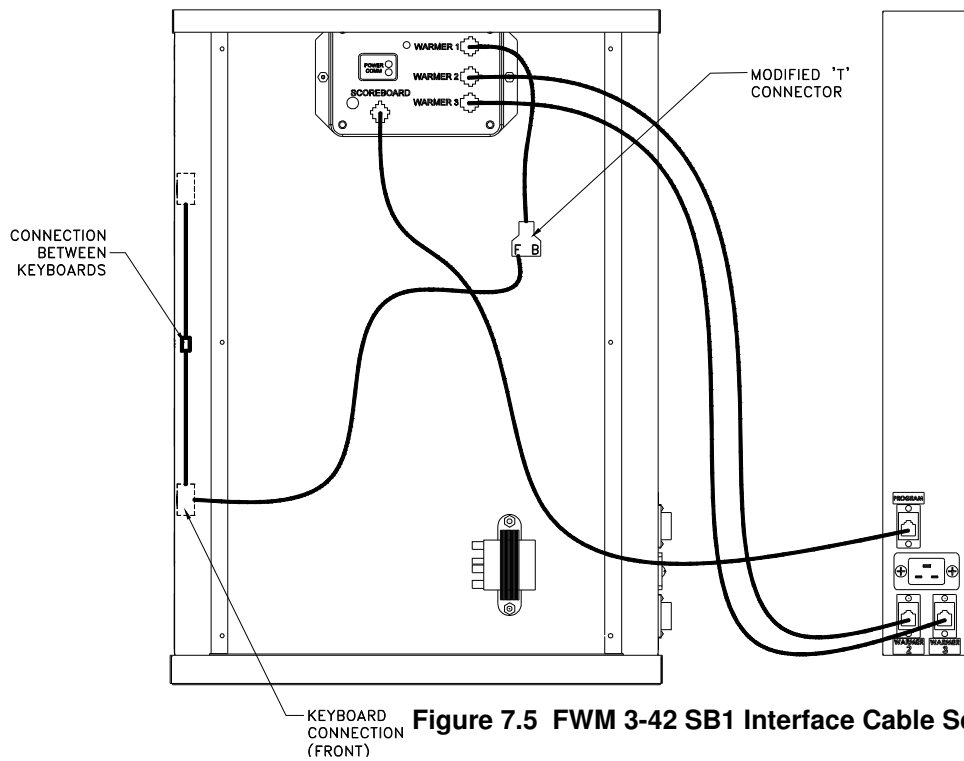

Figure 7.5 FWM 3-42 SB1 Interface Cable Schematic

REVISED:
Feb. 21, 2005

U.S. Patent 6175099, 6262394
Other U.S. and Foreign Patents Pending
DUKE MANUFACTURING CO.
TOLL FREE 800-735-DUKE (3853)
314-231-1130



FWM3-42 Wiring Schematics (Continued)

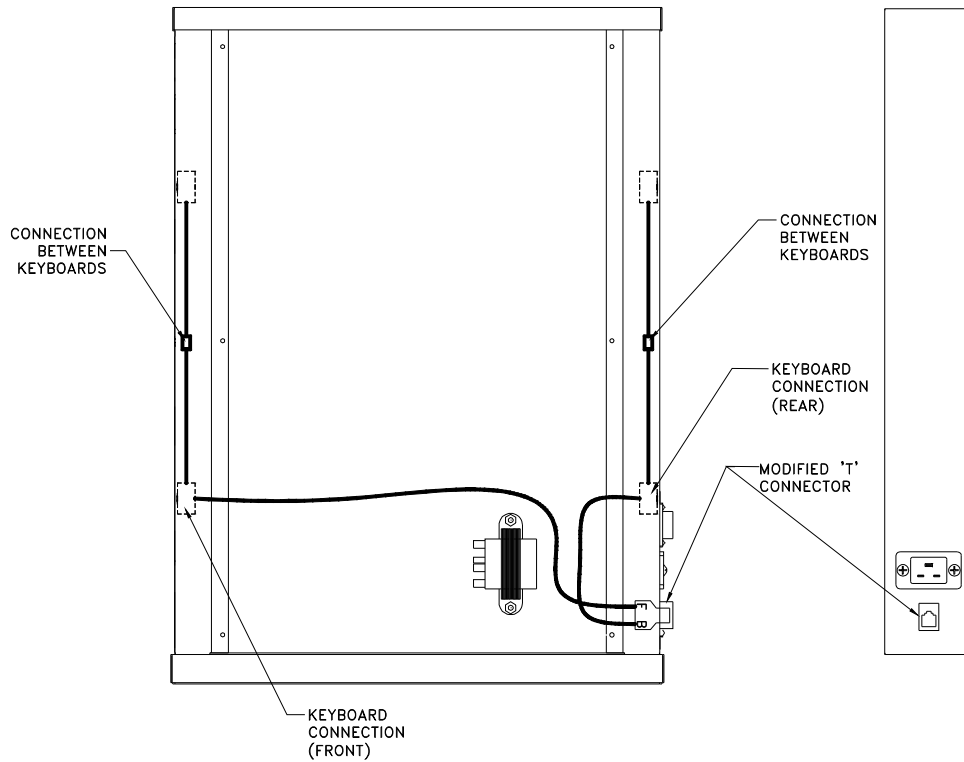

Figure 7.6 FWM 3-42 MB2 & SB2 Interface Cable Schematic

