

FMC FoodTech

**Fresh'n
SQUEEZE**®

Produce Plus Juicer **FMC** FoodTech



For those making or consuming fresh juice anywhere in the world there are certain requirements that must be met.

Those operating the juicer want...

- **Juice** – Good tasting, high quality juice that will turn a profit.
- **Equipment** – Safe, reliable and easy to operate equipment using minimal labor.
- **Juicing Process** – Producing acceptable juice yields at reasonable speeds.
- **Versatility** – Processes a wide variety of fruits and vegetables with minimal preparation time.

Consumers of fresh juice expect...

- **Juice** – Fresh tasting, high quality juice at an affordable price.
- **Equipment** – Clean appearance, sanitary design, and fun to watch.
- **Juicing Process** – Eliminating unwanted seeds, peel, and excess fiber.
- **Versatility** – Delivering consistent juice quality from a wide variety of fruits and vegetables.

Features & Benefits

- **Batch processing using whole fruits** – Saves time on labor; optimizes quality and yield.
- **Industrial Design** – Minimum down-time and maintenance costs.
- **Sanitary Design** – Easy to clean; longer shelf life of juice.
- **Completely Enclosed** – No exposed parts provides safety for operators.
- **Versatility** – Processes and blends most vegetables, fruits and tropicals.



Processing Most Produce Varieties Like: *

Fruits – Apples, Grapes, Pears, Strawberries
Vegetables – Carrots, Celery, Tomato, Beets
Tropicals – Pineapples, Mangos, Guava, Kiwi

The Fresh'n Squeeze® Produce Plus Juicer provides the highest quality and highest yielding juices, using the least amount of labor.

Fresh'n Squeeze[®] Produce-Plus Juicer

Technical Specifications

(metric shown in brackets)

Throughput	15 lbs. (6.8 kg)...4-5 minutes
Fruit Hopper Capacity.....	12-15 lbs. (5.4-6.8 kg)
Processing Capacity.....	48-60 quarts (45-56 liters) per hour
Reservoir Capacity.....	5 Quarts (4.7 liters)
Juicer Dimensions	Height 63-1/2" (162 cm)...Width 24" (61 cm)
	Depth 29" (74 cm)...Weight 350 lbs. (158.7 kg)
Shipping Dimensions.....	Height 73" (186 cm)...Width 30" (76 cm)
	Depth 36" (91 cm)...Weight 375 lbs. (170 kg)
Electrical Requirements (USA)	115 volts...60 Hz...20 amp service...single phase
Electrical Requirements (Export Models)	110/220 volts...50/60 Hz 20/10 amps service...single phase
	(Dedicated Circuit Required)
Safety Features	Completely enclosed, safety interlock switches
Finish.....	High impact, flame retardant ABS
Weight.....	535 lbs. (243 kg)...Shipping Wt. 570 lbs. (259 kg)
Waste Container Holds	40 lbs. (18 kg)
Fruit Size	No restrictions (up to pineapple size)

*** Not recommended for citrus fruit due to high peel oil content. Not recommended for melons due to high pH level. Remove stones and pits in stone fruits first. Kiwi, mango and pineapple must be peeled first.**

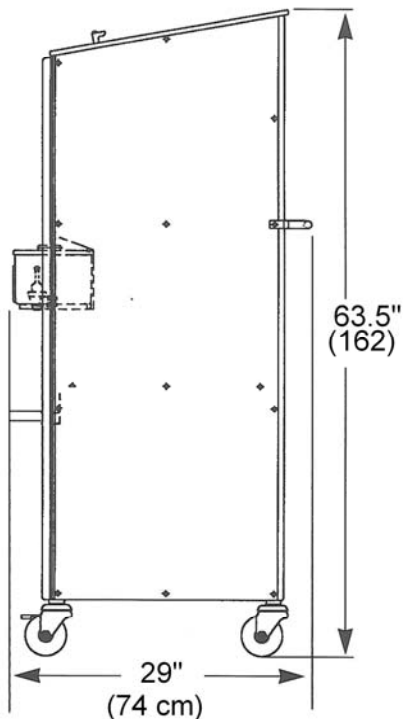

SIDE VIEW
Outside Dimensions

Copyright © FMC Technologies Inc. 2007
FMC FoodTech
400 Fairway Avenue
Lakeland, FL 33801
+1 863 683 5411

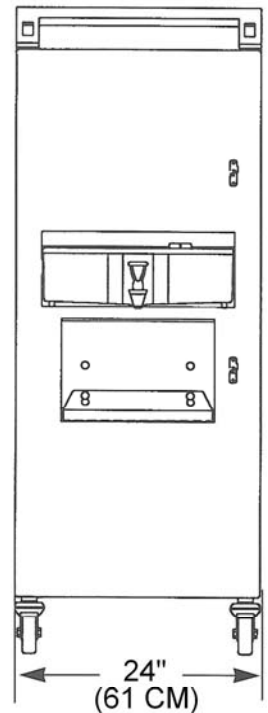

FRONT VIEW
Outside Dimensions

**FMC FOODTECH
CITRUS SYSTEMS**

400 Fairway Avenue
Lakeland, FL 33801
USA

T: +1 863 683 5411
F: +1 863 680 3672

**FMC TECHNOLOGIES
DE MEXICO, SA DE CV**

Carr Mty Saltillo Km 7
Bodega 4
Puerta Las Mitras

Santa Catarina, NL
Mexico 66350
T: +52 818 123 70 55
F: +52 818 123 70 54

**FMC TECHNOLOGIES
DO BRAZIL LTDA**

Av Eng Camilo
Dinucci 4605
14808-900 Araraquara

Sao Paulo Brazil
T: +55 16 3301 2000
F: +55 16 3332 0565

**FMC TECHNOLOGIES
AUSTRALIA LTD.**

Cnr Marple Ave & Biloela St
Villawood New South Wales
2163 Australia

T: +61 2 9723 2000
F: +61 2 9723 2085

**FMC TECHNOLOGIES
HONG KONG LTD**

Rm 3002-3005
Haitong Security Bldg
No. 689 Guangdong Road
Shanghai 20001 China

T: +86 21 6341 1616

FMC FOODTECH, S.L.

C/Julian Camarillo
26-4 Local 2
28037 Madrid Spain

T: +34 91 304 0045
F: +34 91 237 5003